

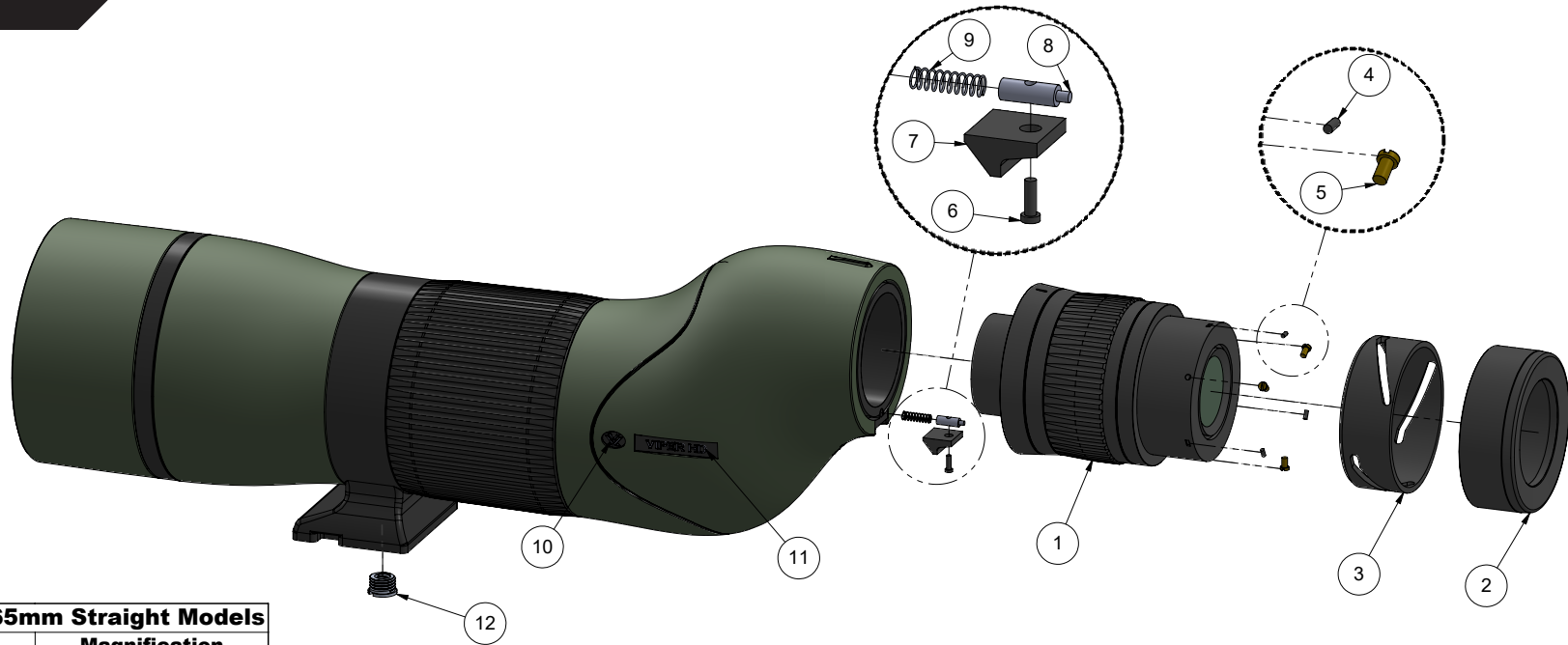

VIPER[®] HD

15-45x65 STRAIGHT SPOTTING SCOPE



Viper [®] HD 65mm Straight Models	
Model	Magnification
V501	15-45x

Parts					In-Box Accessories				
ITEM NO.	PART NUMBER	DESCRIPTION	QTY.	NOTES	ITEM NO.	PART NUMBER	DESCRIPTION	QTY.	NOTES
1	A-00245-0	Viper [®] HD 65mm Zoom Eyepiece Assembly	1			C-02435-0	Viper [®] HD 65mm Straight Neoprene Case	1	
2	C-00660-0	Eyecup Rubber	1			C-00631-0	Objective Lens Cover 65mm	1	
3	C-00659-0	Eyecup Assembly Outer Ring	1			C-02432-0	Eyepiece Lens Cover	1	
4	C-00064-0	Eyecup Tensioner	3			C-02963-0	Lens Cloth	1	
5	C-00658-0	Eyecup Assembly Screw	3			M-00127-2	Viper [®] HD Spotting Scope Owner's Manual	1	
6	C-03396-0	Eyepiece Lock Button Set Screw	1						
7	C-03397-0	Eyepiece Locking Button	1						
8	C-03398-0	Eyepiece Locking Pin	1						
9	C-03399-0	Eyepiece Locking Pin Spring	1						
10	C-00625-0	Oval Badge	2						
11	C-00624-0	Rectangle Badge	2						
12	C-01381-0	Thread Reducer	1						